

TECHNOFORM

Perfis padrão 2025

Soluções para isolamento
de janelas, portas e fachadas.



Perfis padrão para janelas, portas e fachadas

Encontre o seu parceiro perfeito – nossas soluções de perfis padrão

Nosso catálogo padrão oferece mais de 800 geometrias disponíveis para as diversas necessidades de nossos clientes no mundo. Podem se criar soluções de alta qualidade usando os perfis isolantes que aparecem dentro do nosso portfólio padrão. Todos estes produtos podem ser entregues de forma rápida em qualquer comprimento e quantidade a qualquer lugar do mundo já que contamos com uma rede global de 13 centros de produção e mais de 45 escritórios comerciais. Nossos especialistas estão prontos para ajudar e dar suporte com os diversos projetos desde a fase de planejamento e desenvolvimento até o produto acabado.



Poliamida Low Lambda – a ruptura térmica tem um novo valor

Na procura de um valor U_f otimizado, temos desenvolvido um novo padrão: a nossa poliamida Low Lambda. Esta inovação permite oferecer duas possibilidades para atingir seus requisitos. Escolha entre um U_f reduzido enquanto mantendo o mesmo comprimento de marco ou um marco reduzido mantendo o mesmo U_f .



O material e o conteúdo que aparecem neste catálogo são apenas para fins informativos. Technoform oferece assessoramento sobre qualquer dúvida ou consulta previa a toma de decisões comerciais baseadas na informação deste catálogo. Technoform pode mudar o design e funcionalidade dos produtos num exercício de constante inovação e melhora. A Technoform se reserva o direito de mudar as descrições em qualquer momento e de interromper ou retirar qualquer produto em particular durante o ano de validade de este catálogo, sem prévio aviso. Technoform desestima toda responsabilidade por qualquer possível inexatidão ou omissão causada inadvertidamente neste catálogo e as consequências que isso possa acarretar.

Quando se trata de materiais, confie no melhor

Quando se trata de matérias-primas, trabalhamos apenas com os melhores fornecedores. Oferecemos uma grande variedade de materiais, a fim de encontrar a solução personalizada que se adapta às necessidades de cada projeto. Elevada precisão de processo, compatibilidade, produção amiga do ambiente e resistência mecânica excepcional são apenas algumas das vantagens que os nossos materiais oferecem.

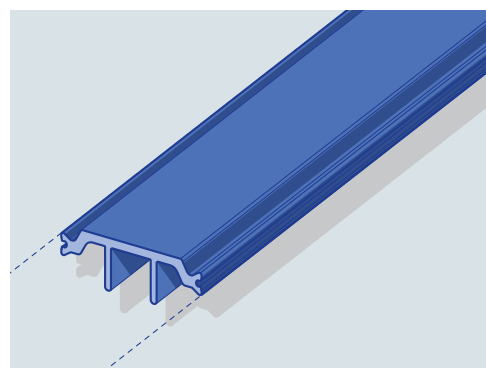

Poliamida standard / PA 66 GF25

Com o nosso material padrão garantimos uma disponibilidade ilimitada, reciclabilidade e um excelente resultado que satisfaz as suas necessidades.

Poliamida Low Lambda

A nossa poliamida Low Lambda oferece um valor Lambda certificado de 0.21 W/(mK), a melhor solução térmica de todas as opções disponíveis no mercado.

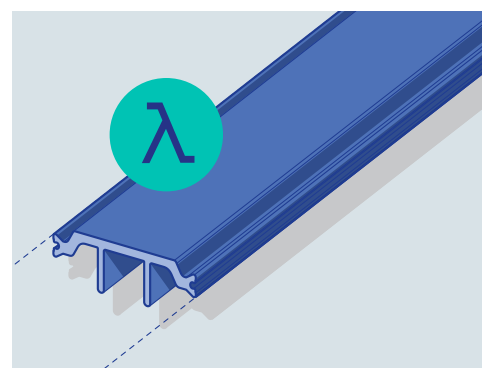

Poliamida reciclada

Para promover a utilização de materiais amigos do ambiente, oferecemos poliamida reciclada que cumpre com os nossos rigorosos padrões de qualidade e de fabrico.

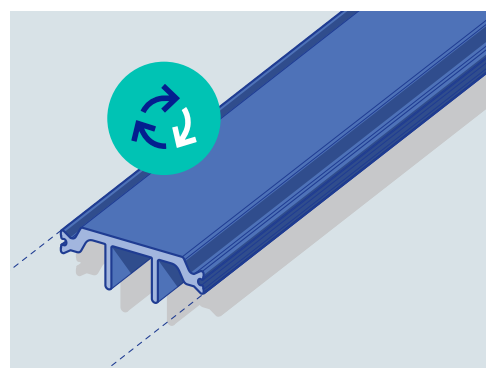

**Low Lambda,
o novo padrão**





























































Perfis padrão de poliamida Low Lambda

Nossos perfis são feitos em Low Lambda PA 66 GF25, resistente ao impacto seco.

000000 Código de Produto / 000000 Novo Produto /

*Produto com produção na América ou Ásia / #Cabeça não compatível com a caixa estândar

















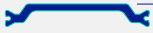





























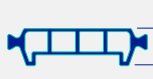





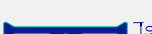





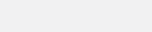

12 mm	16 mm	20 mm	22 mm	23 mm	24 mm	24 mm	26 mm	27 mm	28 mm	29 mm
 839200	 855400	 824300	 817700	 833100	 842400	 828200	 824200	 854800	 863800	 815200
	 856000	 835200	 847500		 853300	24.8 mm	 859700		 809700	 824100
		 830600	 818000		 804100	 848600				 824000
		 834600			 828300	 852900	 857600		 806100	
		 842700			 833800	 804200	 855200		 850300	
		 845700			 866000	 811000	 858800		 803300	
		 829300			 829400	 854700	 863700		 805900	
					 813900	 858500	 857500		 850400	
					 847700	 858400			 809600	
					 834000	 850800			 803200	
					 854100	 845600				
					 853400	 847600				
						 829200				

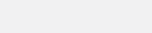
Perfis padrão de poliamida Low Lambda

Nossos perfis são feitos em Low Lambda PA 66 GF25, resistente ao impacto seco.

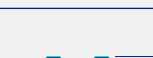



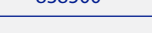
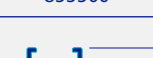

000000 Código de Produto / 000000 Novo Produto /

*Produto com produção na América ou Ásia / #Cabeça não compatível com a caixa estândar

30 mm	32 mm	34 mm	35 mm	36 mm	37 mm	38 mm	39 mm	40 mm	
 846500	 823600	 821100	 838700	 830100	 809900	 829900	 810800	 823400	 841900
 800200	 861700	 807600	 831400	 861300	 840200	 813700	 827300	 805000	 806400
 809800	 803000	 849100	 802800	 821000	 851600	 843600	 801600	 800800	 865600
 860000	 851700	 802200	 838600	 846300		 808000	 842000		
 859800 [#]	 803100	 857900	 855100	 857800 [#]			 827200		
	 806300	 800900	 813300				 805100		
		 833300	 866100				 801500		
		 811800	 811500				 842100		
		 823800	 813200				 821300		
		 833200	 825300				 827100		
		 862200	 838500				 855500		
		 835300	 849200				 801400		

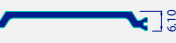







Perfis padrão de poliamida Low Lambda

Nossos perfis são feitos em Low Lambda PA 66 GF25, resistente ao impacto seco.



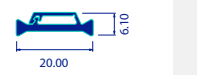
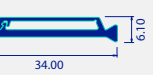

42 mm	44 mm	45 mm	46 mm	48 mm	50 mm
 806800	 810700	 808100	 852600	 861900	 812800
 862500	 863500				 854000
 849900	 863600				
 845400					
 862400					
 840000					
 840100					
 835700					
 835600					
 839900					
 849800					
 862600					

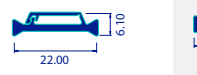
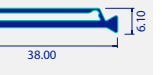
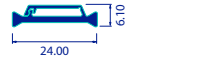
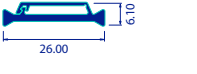
000000 Código de Produto / 000000 Novo Produto /



*Produto com produção na América ou Ásia / #Cabeça não compatível com a caixa estândar

54 mm	55 mm	58 mm	60 mm	Anti bi-metal	
 812600	 833500	 862000	 862100	 835800	 810000
 812500				 850900	 824600
 822900				 835900	 850200
				 835400	
				 851000	

Perfis para portas de correr

 863000
 863400
 851800
 862300*
 843500

Folha oculta

 859600
 864000

Separadores para fachada cortina

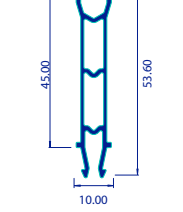
 860900
--

Objetivo: otimizar os seus processos para que tenha tempo para as coisas importantes

O isolamento de janelas, portas e fachadas em alumínio pode sempre ser aperfeiçoado até atingir o seu potencial máximo. As nossas opções de acabamentos foram concebidas para otimizar o seu fluxo de trabalho, permitindo-lhe concentrar-se no que realmente importa.

Cordão termofusível

Acrescentar processos adicionais à linha de produção pode resultar numa perda de tempo e de dinheiro. Com o cordão termofusível pré-instalado nos nossos perfis, minimizamos as perdas de força durante o processo de lacagem causadas pelas altas temperaturas.

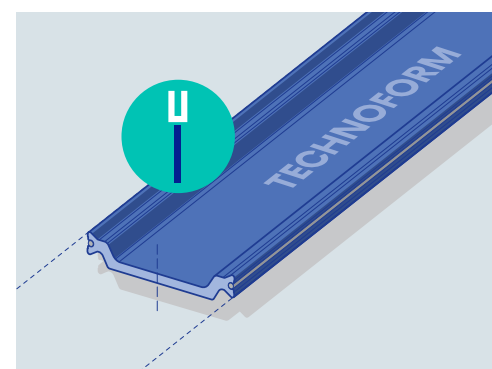
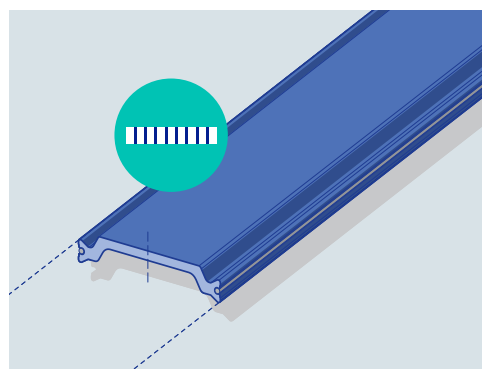

Marcação a laser

São muitas vezes os pequenos pormenores que acrescentam qualidade e funcionalidade a um produto. Ao gravar a laser os nossos perfis de poliamida, conseguimos uma maior visibilidade do logótipo ou da marca da empresa, valorizando o produto, melhorando a sua rastreabilidade e facilitando a otimização logística e o controlo de qualidade.

Filme Adesivo

A preservação do acabamento liso e preto original do perfil de poliamida após a produção é um desafio estético. Por isso, entregamos os perfis com uma película adesiva pré-aplicada para os proteger durante o processo de lacagem. Quando removida posteriormente, o perfil mantém a sua aparência inicial, preservando a sua qualidade estética e acabamento intactos.

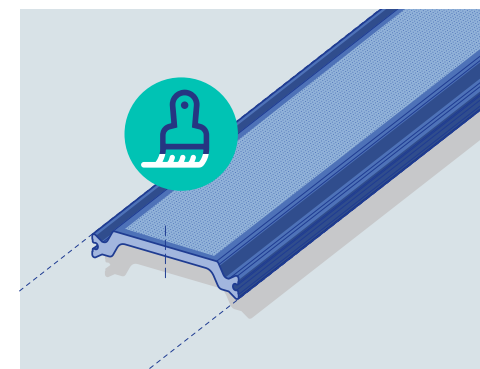
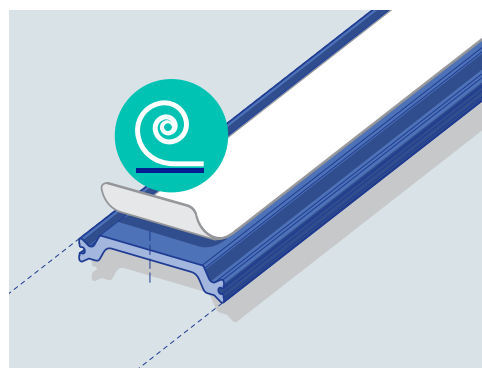

Coating Prime

Obtenha um excelente acabamento de superfície na lacagem da poliamida, otimizando a aplicação da tinta em pó, mantendo a baixa condutividade térmica da poliamida. Coating Prime melhora a aderência da tinta, aumenta a atração do pó e reduz a formação de bolhas durante o processo de polimerização.

Gostamos de desafios

Soluções para janelas e portas de correr

Os sistemas de correr são amplamente valorizados na arquitetura moderna pelo seu equilíbrio entre estética e funcionalidade. Para conseguir um design minimalista e garantir um desempenho térmico eficiente, fabricamos perfis com tolerâncias precisas, formas otimizadas e superfícies lisas que garantem um deslizamento suave e fluido.

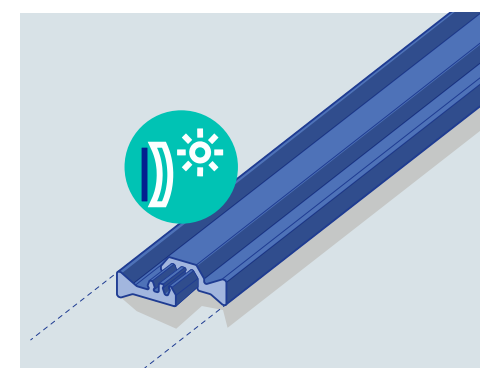
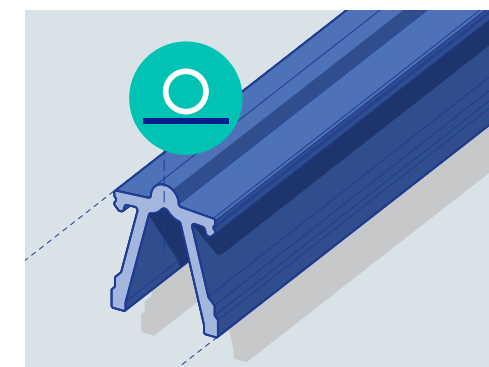

Anti bi-metal

O efeito bimetalico ocorre quando existem grandes diferenças de temperatura entre os perfis interior e exterior de uma porta de alumínio, causando distorção e dificultando a sua abertura. A nossa solução permite que o perfil exterior se dilate sem afetar o fechamento interior, garantindo um funcionamento ótimo e sem problemas.

Draining

A norma francesa NF P24-301 estabelece que as janelas devem contar com orifícios de drenagem para permitir a passagem da água através dos perfis. Entregamos os perfis já mecanizados com estes orifícios, o que permite ao fabricante poupar tempo e valorizar o produto final.

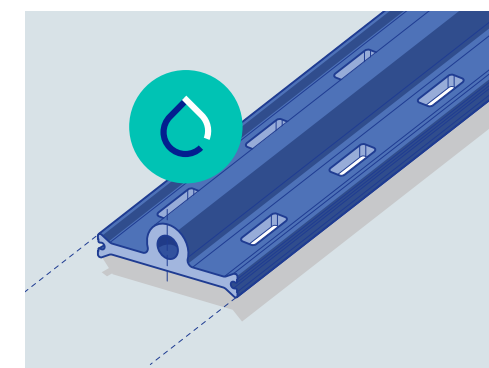

Adhesion Prime - a solução definitiva para a colagem de poliamida com outros materiais

A colagem de componentes em janelas de alumínio com Ruptura da Ponte Térmica é um dos processos mais sensíveis para os projetistas, designers e instaladores. Por este motivo, a Technoform desenvolveu Adhesion Prime, a nova solução patenteada que melhora as características de aderência da poliamida, conseguindo assim uma ligação ótima entre o adesivo e o substrato.

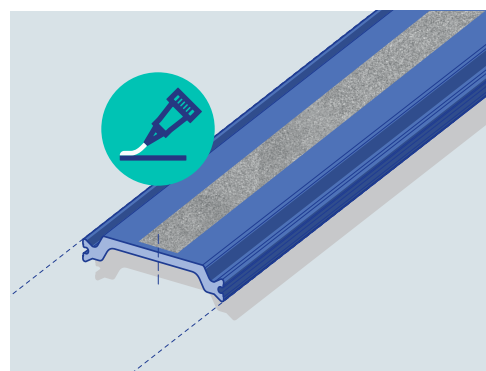

Uma solução inovadora

A capacidade de obter uma adesão ótima entre a poliamida e o substrato abre um leque muito mais vasto de opções de design para sistemas e soluções estruturais, facilitando inovações que anteriormente eram inatingíveis.

Muro-cortina modular

O Adhesion Prime permite a selagem com silicone da unidade de envidraçamento a partir do bordo até um elemento adjacente, normalmente alumínio.

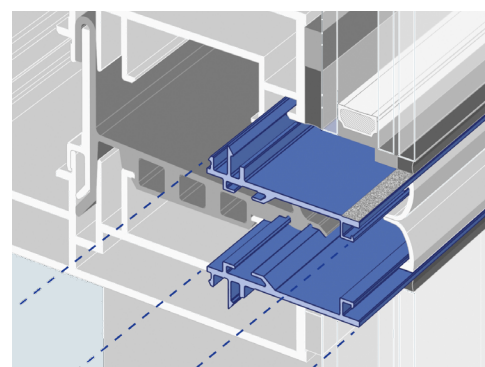

Janelas de folha oculta

O Adhesion Prime facilita a ligação entre o vidro e o perfil da folha através dos perfis de poliamida, conseguindo uma integração mais eficaz entre o vidro e o caixilho. Isso elimina a necessidade de utilizar bite na parte externa do envidraçamento e na junta da folha, o que aumenta a rigidez da estrutura.

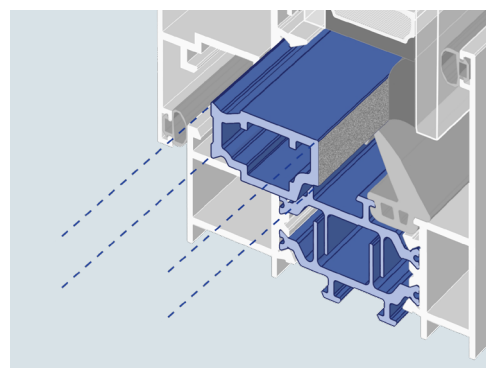

Folha minimalista de sistema deslizante

Com um caixilho reduzido para otimizar a transparência, estes sistemas privilegiam um design limpo e elegante. No entanto, o perfil de poliamida, essencial para um elevado desempenho térmico, pode ser um material fraco para a colagem com outros substratos. O Adhesion Prime permite unir poliamida e vidro com a mesma eficácia que o alumínio, resultando num conjunto robusto e de deslizamento suave.

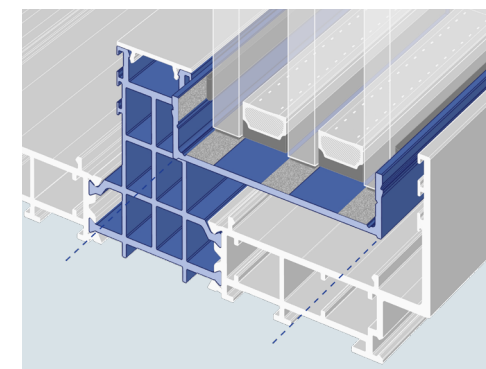

Um mundo de possibilidades

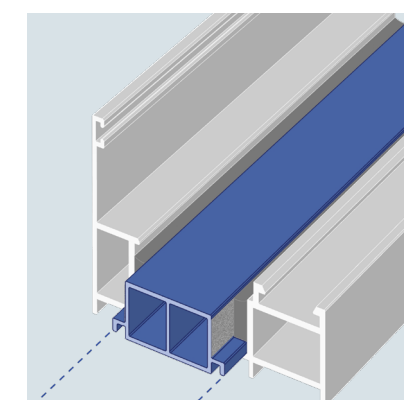
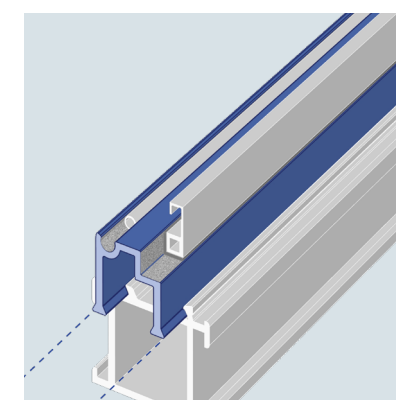
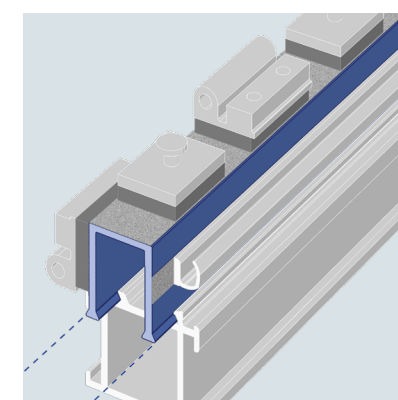
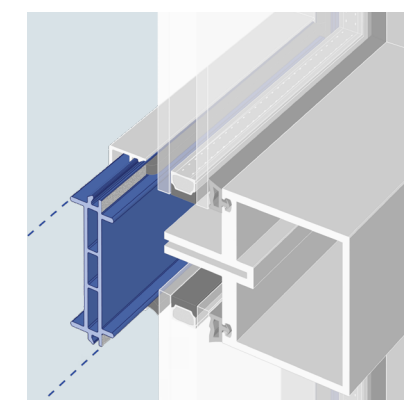
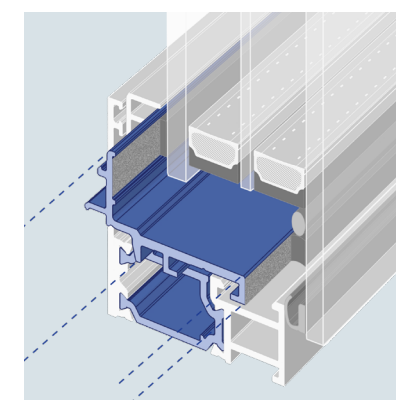
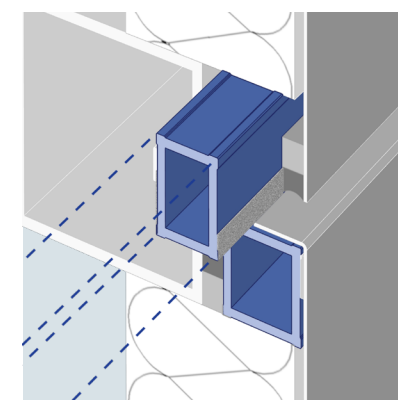
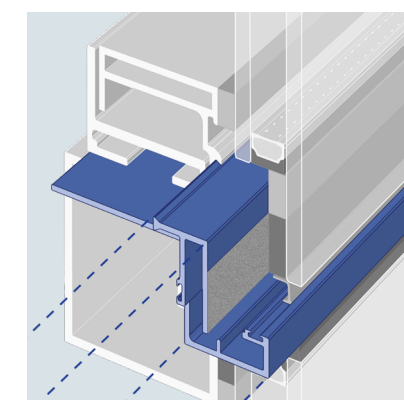
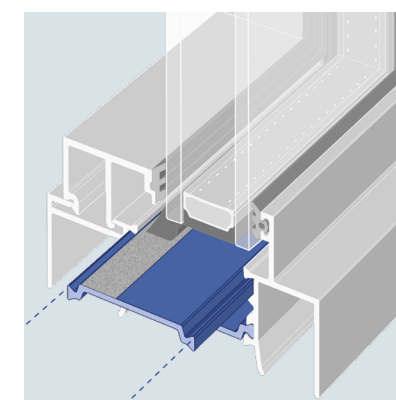
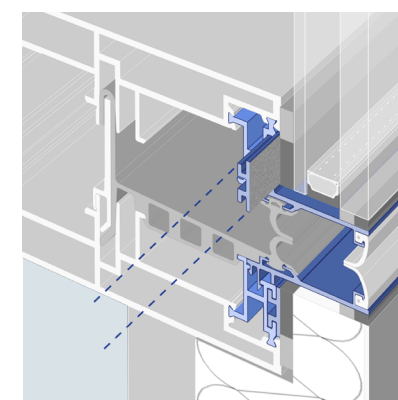

Soluções para fachadas: potenciando a eficiência nos edifícios modernos

Leves, duradouras e elegantes: quando se trata de envoltentes de edifícios comerciais e outros projetos de grande escala, o alumínio é, de forma geral, o material de eleição. Para além do aspeto visual, damos mais um passo no sentido da construção inteligente. As nossas soluções para fachadas em alumínio centram-se no isolamento da envolvente exterior e na otimização do desempenho térmico do conjunto.

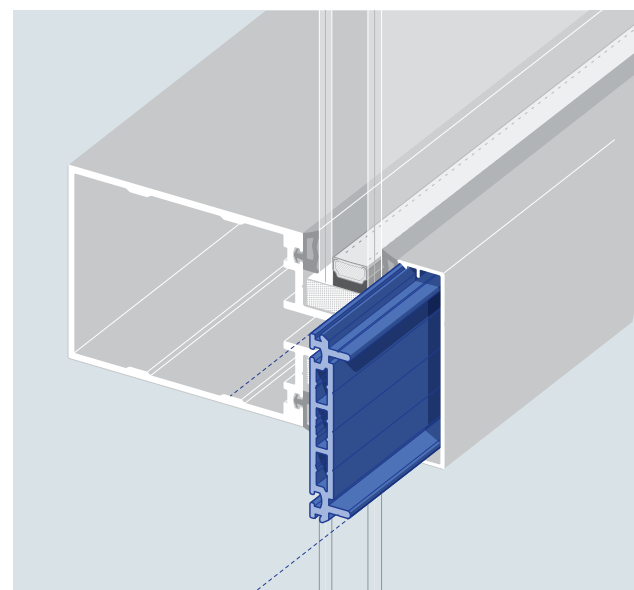

Fachada Stick

Para as fachadas Stick, oferecemos uma gama de mais de 20 espaçadores, bem como placas de pressão em poliamida. As nossas soluções otimizam o desempenho térmico dos sistemas podendo atingir valores U de até 1 W/m²K.

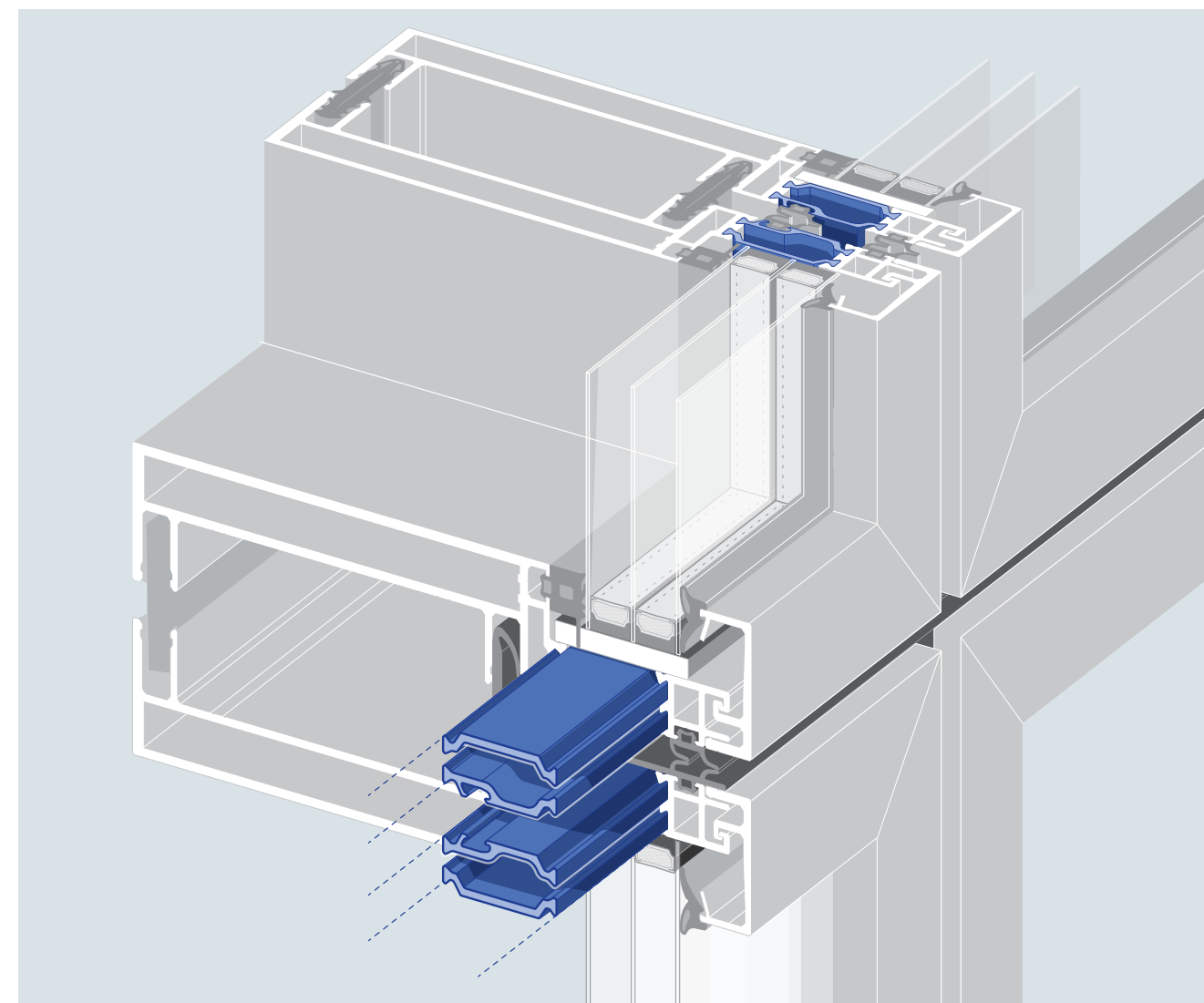
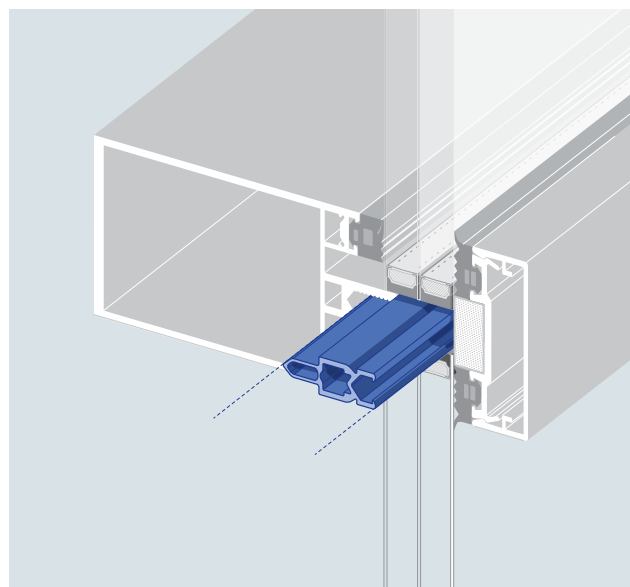

Fachadas modulares



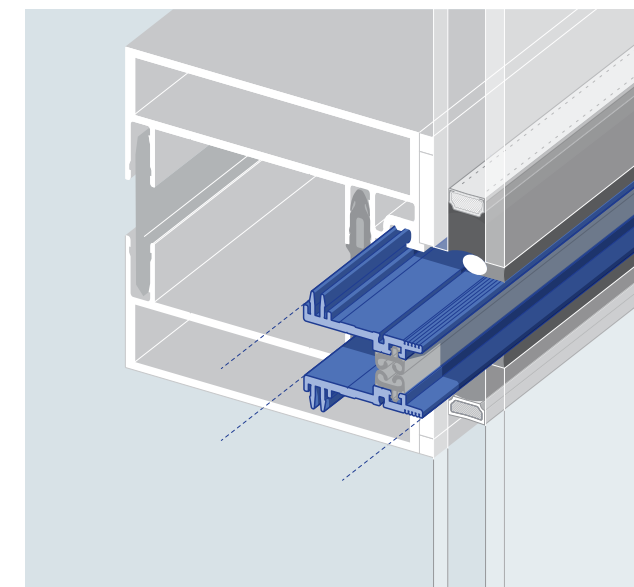

































Todas as nossas soluções isolantes para janelas são válidas para fachadas modulares. Além disso, dispomos de perfis especiais de poliamida para a selagem perimetral para os novos sistemas.





Perfis Padrão PA66 GF25

000000 Código de Produto / 000000 Novo Produto /
 *Produto com produção na América ou Ásia / #Cabeça não compatível com a caixa estandar

9 mm	10 mm	12 mm	13 mm	14 mm
 254000	 204600*	 977500	13.4 mm	 202300
	 244800	 926900 · 975300	 979200	 913700
	 269800*	 209900	13.5 mm	 202400
		 328100	 249100	 217100
		 958241	 969505	 233200*
		 282000		 948600
		 442500*		 493100*
				 486900
				 948700
				 235300
				 240200*
				 980600
				 268200
				 246900
				 247000
			14.6 mm	
				 933900 · 951459
				 919200 · 951159
				 263400
				 259900*
				 951559
				 241600
				 980600
				 268200

Perfis padrão de poliamida

Nossos perfis de PA 66 GF25, resistente ao impacto seco estão disponíveis em opções

000000 Código de Produto / 000000 Novo Produto /

*Produto com produção na América ou Ásia / #Cabeça não compatível com a caixa estandar

14 mm		15 mm			
14.6 mm	14.8 mm				
355700*	371700#	937600	221900	335600#	910300
223900	280600	295600#	403400	320100*	952200#
313000*	931000-951659	299000	221400	257100	538500
216800	486100*	237600	270300	260500	260400
271800	201000	246700	937700		
924300-945500-951259	931100-951759	300800	488200		
203900	941600-951859	271500	977000		
208500	961459	273500			
952100-962059	925500	289700			
406100#	975800	961559			
378600	279000	987400			































































































16 mm			17 mm	18 mm
379100#	940800	977600	296800	589200
962159#	976000	445500	296700	592000
			16.5 mm	
973500	296500	977900	16.5 mm	286600#
				17.4 mm
232900-265800	277600*#	940300	977400	17.4 mm
			16.6 mm	
912000-955900-951359	962259#	981700	16.6 mm	242700#
				17.8 mm
345800#	970559	296600	420800*#	17.8 mm
221000	973600	980900	330400	233800
961859	942100	214400	325300	270200
963900	976100	221100		955000
203200#	265900	227500		622800
219900	941800	270100		541400
270000	961959	296900		267100

Perfis padrão de poliamida

Nossos perfis de PA 66 GF25, resistente ao impacto seco estão disponíveis em opções

000000 Código de Produto / 000000 Novo Produto /

*Produto com produção na América ou Ásia / #Cabeça não compatível com a caixa estândar

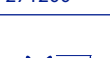
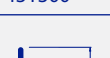
18 mm			19 mm	20 mm		20 mm	21 mm	22 mm		23 mm	
 276900	18.6 mm		 316700	 933200	 228900	 964200	 250000	 556500	 202200	 977200	 283000*
 224100	 210900	 226300	 316900	 912500 · 957600	 499500#	 271100	 439500**	 357500*	 242900	 413800	 538800
 290600	 273300	 276000	 316800	 277400	 387200*	 966500	20.6 mm		 908400	 254100	 320400
 357400*	912100 · 912159		 250800	 957300	 234700	 306700	 221500#	 556400	 269700	 286700	 282600
 955200	 912800	 979300	 246500	 269100*	 325500	 221600#		 966605	 389600		
 277000	 977700	 330500	 941700	 945800	 283600	 978700	 245800				
 343900	 279300*	 952459	 942600	 562100	 493600	 413700	 491600				
 235400	 332700*		 271000	 957400	 297800*	 228100	 439100*				
 322100*	 360500*		 296200	 937000	 924900	 271300*					
 248300	 276800		 976600	 444500	 964100	 243000					
 955300	 324600		 249900	 228700	 271200	 431300					
			 250100	 218500	 330700	 245900					





















































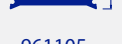





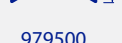









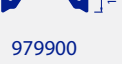

Perfis padrão de poliamida

Nossos perfis de PA 66 GF25, resistente ao impacto seco estão disponíveis em opções



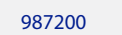

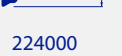







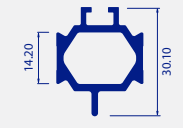







000000 Código de Produto / 000000 Novo Produto /

*Produto com produção na América ou Ásia / #Cabeça não compatível com a caixa estandar

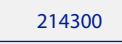

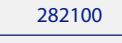









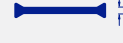

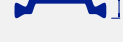

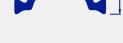
24 mm

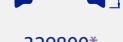
 961759 · 933100	 268000	 220300	 360900	 251800	 359800
 965159*	 294100	 246300*	 566000	 969759	 546100
 919300 · 975900	 976700	 271400*	 322000	 246600	 443700
 390900	 940400	 927200	 495000	 289800	 256800
 241700*	 969959	 925200	 403500	 464600	 273400
 956059	 479800	 975700	 231900	 479700	 464700
 957500	 984300	 404000*	 268100	 502900	 516200
 350300	 961105	 228200	 294200	 330600	 510600
 355000	 979500	 415100	 964300	 228800	 418200
 360800	 459500	 956159	 400800	 300400	 406200*
 954800	 975400	 291100	 979900	 561400	 399200
 235100	 987200	 253600	 224000	 419300	 231800

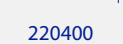



















24 mm

 231800	 578400
 358900	 964559*
 297200	 297100
 214000	 215600
 489900	 246100
 969859	 215700
 962659	 265000
 214800	 214300
 224600	 282100
 413900	 246000
 439400*	

25 mm

 910400	25.3 mm
 979400	 470200*
 950159	 329600*
 974500	 329700*
 249500	 329800*
 946700	25.5 mm
 249600	 220400
 974600	
 249700	
 224600	
 413900	
 439400*	

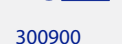
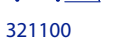
26 mm











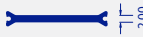









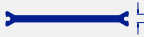

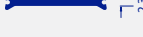





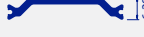

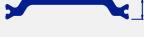

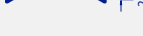

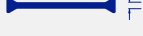

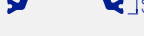









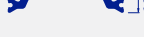

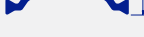
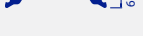

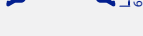

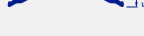

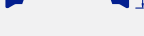





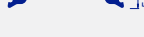

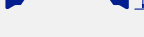

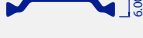

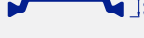

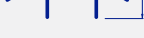

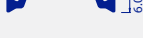

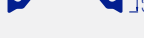

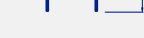





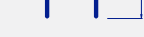





 212600	 410800
 254800	 401700
 908500	 321800
 260600	 978900
 453100	 426400
 304500	 359600
 491200	 394200
 289300*	 208700
 978800	 264100
 357700	 300900
 321100	
 544900*	

Perfis padrão de poliamida

Nossos perfis de PA 66 GF25, resistente ao impacto seco estão disponíveis em opções



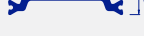
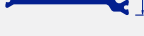

000000 Código de Produto / 000000 Novo Produto /

*Produto com produção na América ou Ásia / #Cabeça não compatível com a caixa estândar

27 mm	28 mm		29 mm	30 mm	30 mm	31 mm	32 mm		34 mm		
 971605	 222500	 354400*	 286800	 404600	 219500	 516600	 247400	 268300	 239300	 418400	 464800
 932000	 948400	 475500	 286900	 220800	 225500	 364500	 354700	 256000	 268400		
 253800	 927700	 355400	 229100	 246200	 493800	 352400	 303700	 256300	 349300		
 253900	 618200	 548200	 308600	 908600	 393000	 368700	 371800	 563100	 478700		
27.5 mm	 214700	 571000	 261900	 273800	 414400	 414300	 256100	 412200	 935100		
 942700	 223500	 321500	 242100	324100#	 241200	 349400	 494500	 218100	 949200		
	 321300	 566100		 282300	 493700	277100**#	 939700	 216100	 986200		
	 516900	 450000		 947400	 974700		 259800	 492100	 438400		
	 368600	 280800		 506200	 312000		 448300	 273900	 265400		
	 509900	 319600		 247300	 282400		247700#	 488300	 384200		
	 450100	 271600		 478600	 364600		 256200		 218600		
	 280900	 975100*		 486400	 247500		 496000		 269200		

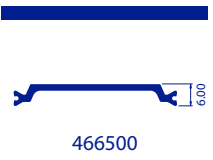
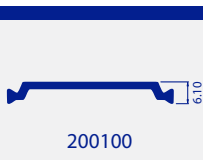
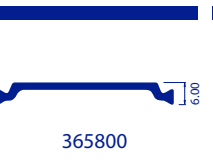
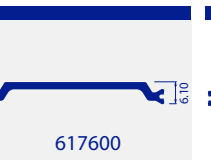
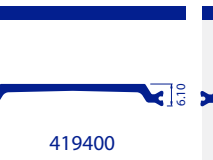
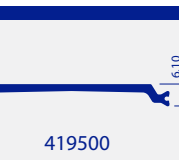
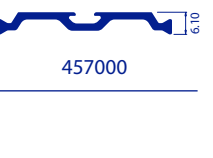
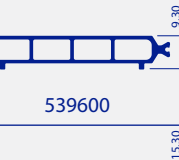
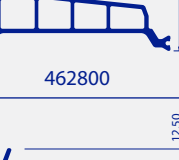
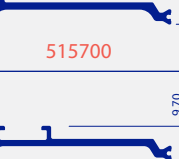
Perfis padrão de poliamida

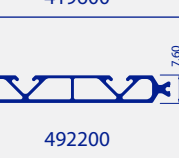
Nossos perfis de PA 66 GF25, resistente ao impacto seco estão disponíveis em opções

45 mm	46 mm	48 mm	49 mm	50 mm	54 mm
 466500	 200100	 365800	 617600	 419400	 419500
		 457000			 539600
					 462800
					 515700
					 515600
					 419600
					 492200

000000 Código de Produto / 000000 Novo Produto /

*Produto com produção na América ou Ásia / #Cabeça não compatível com a caixa estândar

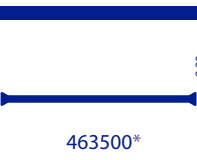
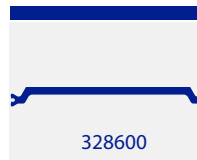
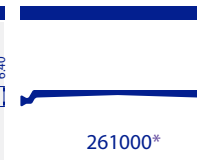
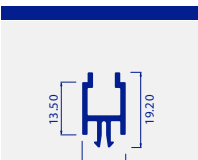
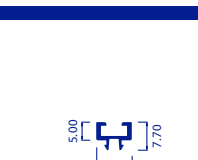
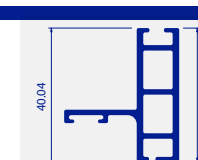
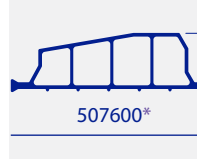
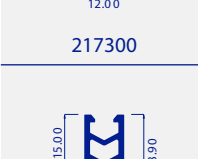
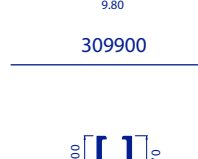
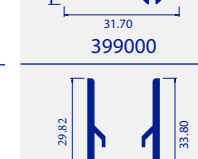
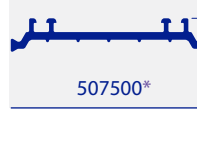
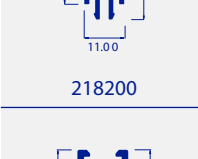
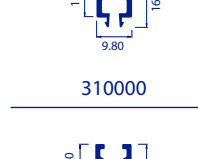
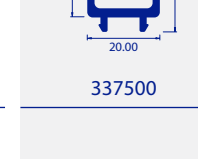
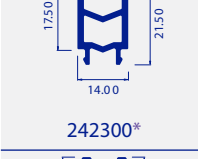
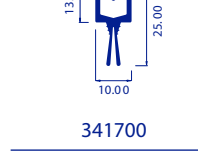
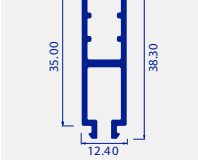
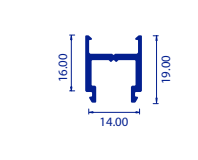
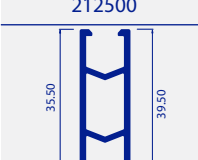
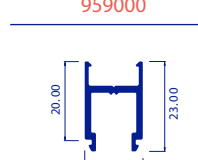
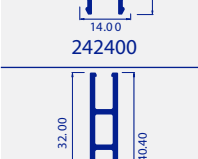
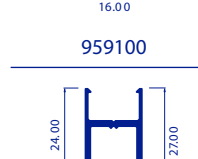
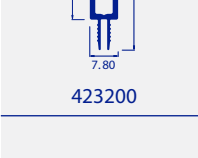
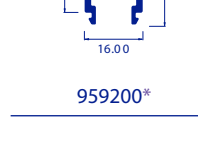
60 mm	64 mm	77 mm	Separadores para Fachada Cortina		
 463500*	 328600	 261000*	 217300	 309900	 399000
	 507600*		 218200	 310000	 337500
	 507500*		 242300*	 341700	 337400
			 212500	 959000	
			 242400	 959100	
			 423200	 959200*	
			 248800*	 472500*	
			 280100	 398900	













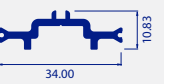
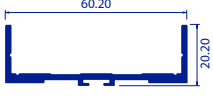

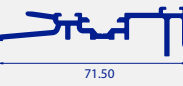
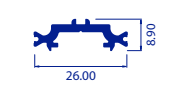



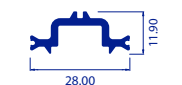
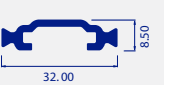
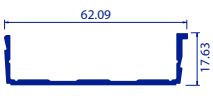
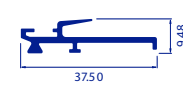

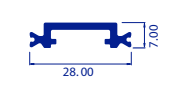

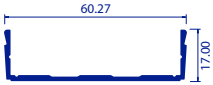
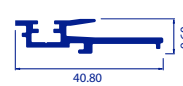

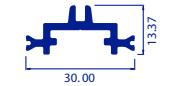

Perfis padrão de poliamida

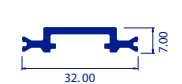
Nossos perfis de PA 66 GF25, resistente ao impacto seco estão disponíveis em opções

000000 Código de Produto / 000000 Novo Produto /

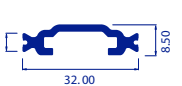
*Produto com produção na América ou Ásia / #Cabeça não compatível com a caixa estandar

Perfis pletina	Especiais	Folha oculta	Anti bi-metal		
 224400	 200600	 346000	 458800	 339000	 576000
 222400	 212100	 620400	 317000	 464400	 605100
 218000	 254400	 375400	 370000	 429900	 599900
 601100	 492000	 464900	 317100	 520900	 598700
 289400*	 432100*	 529500	 339900	 521000	 590900
 254700	 491700*	 506400	 316200		 592400
 224500	 449500*	 550600	 387500		 605200*
		 513400	 418100		

Perfis para portas de correr				Perfis para portas de correr minimalistas
 200500	 389900	 437700	 274000	 440100
 979600	 486200	 301000	 245000	 440200
 244900	 371900	 618300	 306200#	 440300
 343200	 977100	 255300	 354300	 440400
 385200	 933000	 263000	 384300	
 403600	 385100	 282200	 959300	
 415500	 306300	 419000#		
 311300	 229000	 495600		

Folha de características do material

Perfis isolantes de **PA 66 GF25, resistente ao impacto seco**

Caraterísticas	Norma de referência	Unidade	Amostras preparadas de perfis isolantes estruídos		Amostras de modelagem por injeção
			Secas ⁽¹⁾	Estabilizadas em humidade ⁽²⁾	Secas ⁽¹⁾
temperatura de fusão	EN ISO 11357-3	°C	min. 250 ⁽³⁾	min. 250 ⁽³⁾	min. 250 ⁽³⁾
densidade	EN ISO 1183-1 ou -3	g/cm ³	1.3 +/- 0.05	1.3 +/- 0.05	1.3 +/- 0.05
resíduo de calcinação (conteúdo de fibra de vidro)	EN ISO 1172	%	25 +/- 2.5	25 +/- 2.5	25 +/- 2.5
dureza shore D	EN ISO 868	-	82 +/- 4 ⁽⁴⁾	78 +/- 4 ⁽⁴⁾	84 +/- 2
resistencia ao impacto	EN ISO 179-1	kJ/m ²	min. 30 ou sem rotura ⁽⁵⁾	min. 40 ou sem rotura ⁽⁵⁾	min. 35 ⁽⁶⁾
resistencia a tração	EN ISO 527-2 e -4	N/mm ²	min. 80 ⁽⁷⁾	min. 50 ⁽⁷⁾	min. 110 ⁽⁸⁾
módulo de Young	EN ISO 527-2 e -4	N/mm ²	min. 4500 ⁽⁷⁾	min. 2000 ⁽⁷⁾	min. 6000 ⁽⁸⁾
deformação a rotura	EN ISO 527-2 e -4	%	min. 3 ⁽⁷⁾	min. 7 ⁽⁷⁾	min. 3 ⁽⁸⁾

¹⁾ Conteúdo de água na amostra inferior à 0.2 % em peso.

²⁾ Acondicionamiento rápido segundo EN ISO 1110 (23 °C / 50 %)

³⁾ Temperatura máxima de ensaio 300 °C

⁴⁾ Espessura de proveta de 2 mm

⁵⁾ Proveta tipo 2fU (50 mm x 10 mm x 2 mm)

⁶⁾ Proveta tipo 1fU (80 mm x 10 mm x 4 mm)

⁷⁾ Proveta tipo 1BA

⁸⁾ Proveta tipo 1A

No caso de precisar de informação mais precisa, estamos encantados de poder ajudar.

Folha de características do material

Perfis isolantes de **Low Lambda PA 66 GF25, resistente ao impacto seco**

Caraterísticas	Norma de referência	Unidade	Amostras preparadas de perfis isolantes estruídos	
			Secas ⁽¹⁾	Estabilizadas em humidade ⁽²⁾
temperatura de fusão	EN ISO 11357-3	°C	min. 250 ⁽³⁾	min. 250 ⁽³⁾
densidade	EN ISO 1183-1 ou -3	g/cm ³	1.0 +/- 0.1	1.0 +/- 0.1
resíduo de calcinação (conteúdo de fibra de vidro)	EN ISO 1172	%	25 +/- 2.5	25 +/- 2.5
dureza shore D	EN ISO 868	-	77 +/- 4 ⁽⁴⁾	67 +/- 4 ⁽⁴⁾
resistencia ao impacto	EN ISO 179-1	kJ/m ²	min. 20 ⁽⁵⁾	min. 30 ⁽⁵⁾
resistencia a tração	EN ISO 527-2 e -4	N/mm ²	min. 50 ⁽⁶⁾	min. 35 ⁽⁶⁾
módulo de Young	EN ISO 527-2 e -4	N/mm ²	min. 2900 ⁽⁶⁾	min. 1300 ⁽⁶⁾
deformação a rotura	EN ISO 527-2 e -4	%	min. 3 ⁽⁶⁾	min. 8 ⁽⁶⁾

¹⁾ Conteúdo de água na amostra inferior à 0.2 % em peso

²⁾ Acondicionamiento rápido segundo EN ISO 1110 (23 °C / 50 %)

³⁾ Temperatura máxima de ensaio 300 °C

⁴⁾ Espessura de proveta de 2 mm

⁵⁾ Proveta tipo 2fU (50 mm x 10 mm x 2 mm)

⁶⁾ Proveta tipo 1BA

No caso de precisar de informação mais precisa, estamos encantados de poder ajudar.

Folha de características do material

Perfis isolantes de **PA 66 GF25 Reciclado**, resistente ao impacto seco



Caraterísticas	Norma de referência	Unidade	Amostras preparadas de perfis isolantes estruídos		Amostras de modelagem por injeção
			Secas ⁽¹⁾	Estabilizadas em humidade ⁽²⁾	Secas ⁽¹⁾
temperatura de fusão	EN ISO 11357-3	°C	min. 250 ⁽³⁾	min. 250 ⁽³⁾	min. 250 ⁽³⁾
densidade	EN ISO 1183-1 ou -3	g/cm ³	1.3 +/- 0.05	1.3 +/- 0.05	1.3 +/- 0.05
resíduo de calcinação (conteúdo de fibra de vidro)	EN ISO 1172	%	25 +/- 2.5	25 +/- 2.5	25 +/- 2.5
dureza shore D	EN ISO 868	-	82 +/- 4 ⁽⁴⁾	78 +/- 4 ⁽⁴⁾	84 +/- 2
resistencia ao impacto	EN ISO 179-1	kJ/m ²	min. 30 ou sem rotura ⁽⁵⁾	min. 40 ou sem rotura ⁽⁵⁾	min. 35 ⁽⁶⁾
resistencia a tração	EN ISO 527-2 e -4	N/mm ²	min. 80 ⁽⁷⁾	min. 50 ⁽⁷⁾	min. 110 ⁽⁸⁾
módulo de Young	EN ISO 527-2 e -4	N/mm ²	min. 4500 ⁽⁷⁾	min. 2000 ⁽⁷⁾	min. 6000 ⁽⁸⁾
deformação a rotura	EN ISO 527-2 e -4	%	min. 3 ⁽⁷⁾	min. 7 ⁽⁷⁾	min. 3 ⁽⁸⁾

- ¹⁾ Conteúdo de água na amostra inferior à 0.2 % em peso.
- ²⁾ Acondicionamiento rápido segundo EN ISO 1110 (23 °C / 50 %)
- ³⁾ Temperatura máxima de ensaio 300 °C
- ⁴⁾ Espessura de proveta de 2 mm
- ⁵⁾ Proveta tipo 2fU (50 mm x 10 mm x 2 mm)
- ⁶⁾ Proveta tipo 1fU (80 mm x 10 mm x 4 mm)
- ⁷⁾ Proveta tipo 1BA
- ⁸⁾ Proveta tipo 1A
- ⁹⁾ A poliamida 66 utilizada é composta 100% por materiais reciclados pós-industriais

No caso de precisar de informação mais precisa, estamos encantados de poder ajudar.

Folha de características do material

Perfis isolantes de **Low Lambda PA 66 GF25 Reciclado**, resistente ao impacto seco



Caraterísticas	Norma de referência	Unidade	Amostras preparadas de perfis isolantes estruídos	
			Secas ⁽¹⁾	Estabilizadas em humidade ⁽²⁾
temperatura de fusão	EN ISO 11357-3	°C	min. 250 ⁽³⁾	min. 250 ⁽³⁾
densidade	EN ISO 1183-1 ou -3	g/cm ³	1.0 +/- 0.1	1.0 +/- 0.1
resíduo de calcinação (conteúdo de fibra de vidro)	EN ISO 1172	%	25 +/- 2.5	25 +/- 2.5
dureza shore D	EN ISO 868	-	77 +/- 4 ⁽⁴⁾	67 +/- 4 ⁽⁴⁾
resistencia ao impacto	EN ISO 179-1	kJ/m ²	min. 20 ⁽⁵⁾	min. 30 ⁽⁵⁾
resistencia a tração	EN ISO 527-2 e -4	N/mm ²	min. 50 ⁽⁶⁾	min. 35 ⁽⁶⁾
módulo de Young	EN ISO 527-2 e -4	N/mm ²	min. 2900 ⁽⁶⁾	min. 1300 ⁽⁶⁾
deformação a rotura	EN ISO 527-2 e -4	%	min. 3 ⁽⁶⁾	min. 8 ⁽⁶⁾

- ¹⁾ Conteúdo de água na amostra inferior à 0.2 % em peso
- ²⁾ Acondicionamiento rápido segundo EN ISO 1110 (23 °C / 50 %)
- ³⁾ Temperatura máxima de ensaio 300 °C
- ⁴⁾ Espessura de proveta de 2 mm
- ⁵⁾ Proveta tipo 2fU (50 mm x 10 mm x 2 mm)
- ⁶⁾ Proveta tipo 1BA
- ⁷⁾ A poliamida 66 utilizada é composta 100% por materiais reciclados pós-industriais

No caso de precisar de informação mais precisa, estamos encantados de poder ajudar.

Colaboradores

Europa

- Federation of European Window and Curtain Wall Manufacturers' Associations

Bélgica e Países Baixos

- BUtgb vzw - UBAtc asbl - Belgian Union for Technical Approval in Construction
- FAC - Federatie Aluminium Constructeurs
- VMRG - Vereniging van Metalen Ramen - en Gevelfabrikanten

França

- CSTB - Centre Scientifique et Technique du Bâtiment
- SNFA - Syndicat National de la Construction des Fenêtres, Façades et Activités Associées

Alemanha

- IFT-Rosenheim - Institut für Fenstertechnik e.V.
- FIW-München - Forschungsinstitut für Wärmeschutz e.V.
- IFZ - Informationszentrum Fenster Türen Fassaden e.V.
- VFF - Verband der Fenster- und Fassadenhersteller
- Bundesdeutscher Arbeitskreis für Umweltbewusstes Management (B.A.U.M.) e.V.
- A/U/F Aluminium und Umwelt im Fenster- und Fassadenbau
- EPEA Internationale Umweltforschung GmbH
- Deutsche Gesellschaft für Nachhaltiges Bauen

Grande Bretanha

- CAB - Council for Aluminium in Building
- BFRC - British Fenestration Rating Council

Itália

- UNICMI - Unione nazionale delle Industrie delle Costruzioni Metalliche dell'Involucro e dei serramenti
- AITAL / QUALITAL - Associazione Italiana Trattamenti superficiali Alluminio / Organismo di Certificazione

Portugal

- ANFAJE - Associação Nacional dos Fabricantes de Janelas Eficientes
- APAL - Associação Portuguesa Do Alumínio

Espanha

- AEA - Asociación Española del Aluminio y Tratamientos de Superficie
- ASEFAVE - Asociación Española de Fabricantes de Fachadas Ligeras y Ventanas
- Tecnalía Research & Innovation
- ENSATEC - Laboratorio de Ensayos Tecnológicos

América

Norte América

- FGIA - Fenestration and Glazing Industry Alliance
- AEC - Aluminum Extruders Council
- NGA - National Glass Association
- NFRC - National Fenestration Rating Council
- FTI - Façade Tectonics Institute

Sul América

- CAIAMA - Cámara Argentina de la Industria del Aluminio y Metales Afines.
- Brasil AFEAL - Associação Nacional de Fabricantes de Esquadrias de Alumínio.
- AMEVEC - Asociación Mexicana de Ventanas y Cerramientos

Ásia

China

- CAIGA - China Architectural and Industrial Glass Assn.
- CCMSA - China Construction Metal Structure Assn.
- Hong Kong Facade Association
- National Committee of Standardization for Non-ferrous Metals

Korea

- KAFA - Korea Architectural Facade Association

Singapore

- SGBC - Singapore Green Building Council
- BCA - Building and Construction Authority of Singapore
- ESI - Energy Studies Institute - National University of Singapore

Oceânia

Austrália & Nova Zelândia

- WGANZ - Window & Glass Association New Zealand
- AGWA - Australian Glass & Window Association
- IGMA - Insulating Glass Manufacturers Alliance

Certificações



Europa

TÜV Certification

de acordo com
ISO 9001:2015

Cradle to Cradle Certified®

Gold level Material Health Certificate
Environmental Product Declaration

Alemanha

TÜV Certification

de acuerdo con
ISO 14001:2015
ISO 50001:2018
ISO 45001:2018

Itália

TÜV Certification

de acordo com
ISO 4500:2018
ISO 14021:2021

RINA Certification

de acordo com ISO 45001

Bélgica

ATG Certification

Norte América

TÜV Certification

de acuerdo con ISO 9001:2015

Rússia

GOST Certification

Cradle to Cradle Certified®

Gold level Material Health Certificate

China

TÜV Certification

de acordo com
ISO 14001:2015
ISO 9001:2015
ISO 45001:2018

Hong Kong

TÜV Certification

de acordo com
ISO 14001:2015
ISO 9001:2015
ISO 45001:2018

Singapore

Singapore Green Building Product - Excellent

Estamos em todo o mundo - mais perto do que imagina.



Europa

Balcãs c/o Milan office
Telefone: +39 02 9375 721

Bélgica Tournai
Telefone: +32 10 396 900

França Lyon
Telefone: +33 762 047301

Alemanha Kassel
Telefone: +49 561 9583400

Kassel
Telefone: +49 561 207530

Grande Bretanha Alcester
Telefone: +44 1789 761323

Grécia a/c oficina de Milán
Telefone: +39 02 9375 721

Itália Milán
Telefone: +39 02 9375 721

Espanha Barcelona
Telefone: +34 932 386 438

Tordesillas
Telefone: +34 983 796 632

Turquia a/c oficina de Milán
Telefone: +39 02 9375 721

América

Norte América Twinsburg, OH
Telefone: +1 330 4876600

McMinnville, OR
Telefone: +1 971 8320502

Kingsport, TN
Telefone: +1 423 2021812

Sul América São Paulo
Telefone: +55 11 96573 7527

Argentina
Telefone: +54 911 4565 5758

Ásia

China Suzhou
Telefone: +86 512 62833188

Beijing
Telefone: +86 010 65907177

Shenzhen
Telefone: +86 755 26727912

Shanghai
Telefone: +86 21 62611991

Shenyang
Telefone: +86 24 23963791

Hong Kong
Telefone: +852 2665 6322

Chengdu
Telefone: +86 28 84397818

Linq
Telefone: +86 139 5240 2431

Hangzhou
Telefone: +86 139 1211 0144

Xi'an
Telefone: +86 139 6219 3080

Tianjin
Telefone: +86 186 2214 2389

Índia Bombay
Telefone: +91 96 19333880

Japão Tokio
Telefone: +81 3 55799454

Korea Seúl
Telefone: +82 2 5017357

Oriente Meio Dubai, UAE
Telefone: +971 4 3215615

Singapore Ciudad de Singapur
Telefone: +65 62739595

Taiwan Taipéi
Telefone: +86 150 1251 6795

Oceânia

Austrália Melbourne
Telefone: +61 3 88445582

Nova Zelândia Auckland
Telefone: +64 9415 9050

TECHNOFORM

www.technoform.com